

# Music Engineering Laboratory - Hardware Schematic

8/27/2017

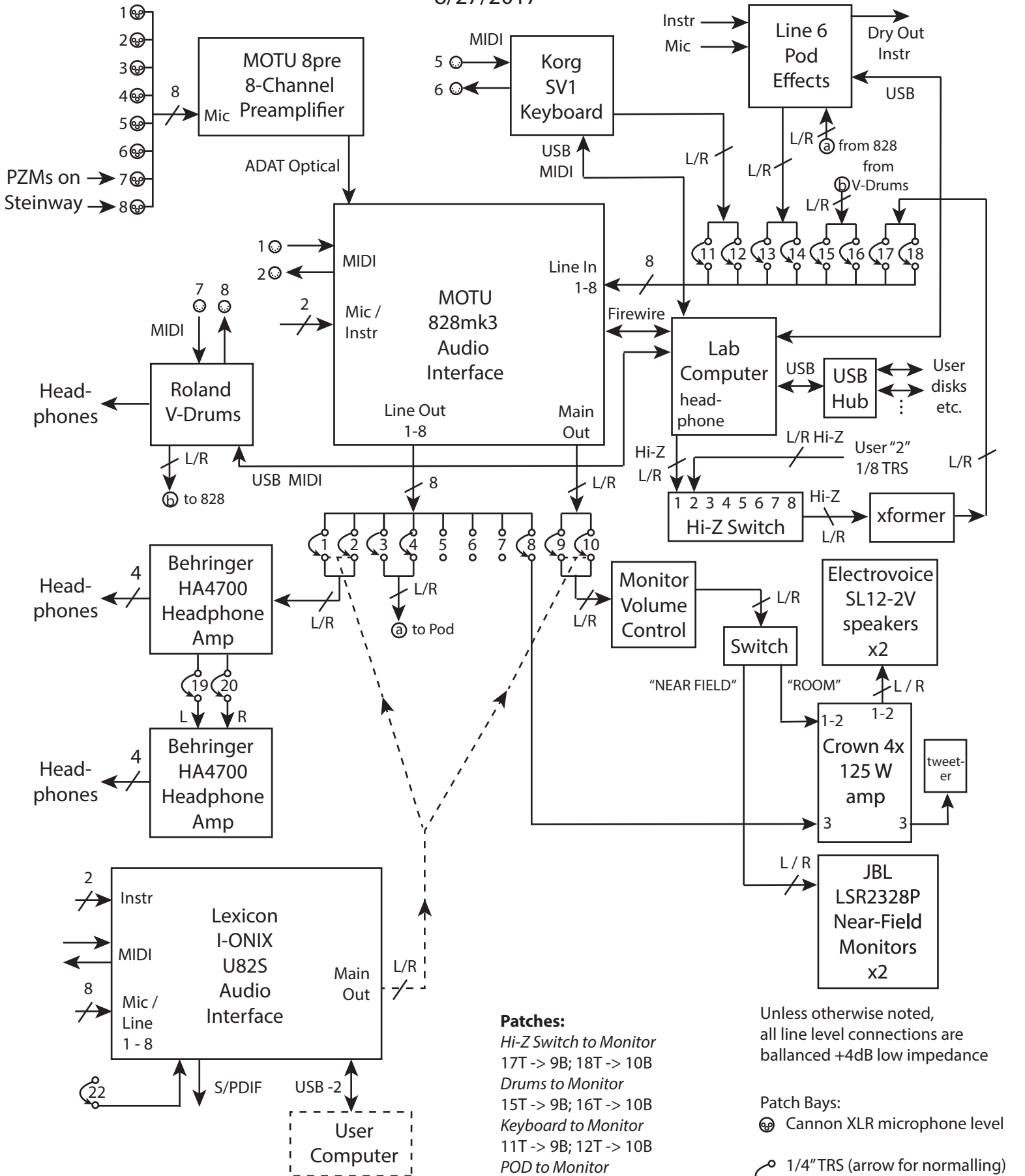

**Patches:**  
 Hi-Z Switch to Monitor  
 17T -> 9B; 18T -> 10B  
 Drums to Monitor  
 15T -> 9B; 16T -> 10B  
 Keyboard to Monitor  
 11T -> 9B; 12T -> 10B  
 POD to Monitor  
 13T -> 9B; 14T -> 10B

Unless otherwise noted,  
 all line level connections are  
 balanced +4dB low impedance

Patch Bays:  
 ☉ Cannon XLR microphone level

↻ 1/4" TRS (arrow for normalling)  
 plug into lower jack to take over

☉ MIDI